

# **User's Guide**

## **Agilent Technologies ESA-E Series Spectrum Analyzers Cable Fault Measurement Personality Option 225**



**Manufacturing Part Number: E4401-90312**

**Printed in USA**

**May 2001**

Supersedes E4401-90226

© Copyright 2000, 2001 Agilent Technologies, Inc.

---

## Notice

The information contained in this document is subject to change without notice.

Agilent Technologies makes no warranty of any kind with regard to this material, including but not limited to, the implied warranties of merchantability and fitness for a particular purpose. Agilent Technologies shall not be liable for errors contained herein or for incidental or consequential damages in connection with the furnishing, performance, or use of this material.

---

## Warranty

This Agilent Technologies instrument product is warranted against defects in material and workmanship for a period of three years from date of shipment. During the warranty period, Agilent Technologies Company will, at its option, either repair or replace products that prove to be defective.

For warranty service or repair, this product must be returned to a service facility designated by Agilent Technologies. Buyer shall prepay shipping charges to Agilent Technologies and Agilent Technologies shall pay shipping charges to return the product to Buyer. However, Buyer shall pay all shipping charges, duties, and taxes for products returned to Agilent Technologies from another country.

Agilent Technologies warrants that its software and firmware designated by Agilent Technologies for use with an instrument will execute its programming instructions when properly installed on that instrument. Agilent Technologies does not warrant that the operation of the instrument, or software, or firmware will be uninterrupted or error-free.

---

## LIMITATION OF WARRANTY

The foregoing warranty shall not apply to defects resulting from improper or inadequate maintenance by Buyer, Buyer-supplied software or interfacing, unauthorized modification or misuse, operation outside of the environmental specifications for the product, or improper site preparation or maintenance.

NO OTHER WARRANTY IS EXPRESSED OR IMPLIED. AGILENT TECHNOLOGIES SPECIFICALLY DISCLAIMS THE IMPLIED WARRANTIES OF MERCHANTABILITY AND FITNESS FOR A PARTICULAR PURPOSE.

---

## EXCLUSIVE REMEDIES

THE REMEDIES PROVIDED HEREIN ARE BUYER'S SOLE AND EXCLUSIVE REMEDIES. AGILENT TECHNOLOGIES SHALL NOT BE LIABLE FOR ANY DIRECT, INDIRECT, SPECIAL, INCIDENTAL, OR CONSEQUENTIAL DAMAGES, WHETHER BASED ON CONTRACT, TORT, OR ANY OTHER LEGAL THEORY.

---

## Safety Information

The following safety notes are used throughout this manual. Familiarize yourself with these notes before operating this instrument.

---

**WARNING**                      **Warning denotes a hazard. It calls attention to a procedure which, if not correctly performed or adhered to, could result in injury or loss of life. Do not proceed beyond a warning note until the indicated conditions are fully understood and met.**

---

---

**CAUTION**                      Caution denotes a hazard. It calls attention to a procedure that, if not correctly performed or adhered to, could result in damage to or destruction of the instrument. Do not proceed beyond a caution sign until the indicated conditions are fully understood and met.

---

---

**WARNING**                      **This is a Safety Class 1 Product (provided with a protective earth ground incorporated in the power cord). The mains plug shall be inserted only in a socket outlet provided with a protected earth contact. Any interruption of the protective conductor inside or outside of the product is likely to make the product dangerous. Intentional interruption is prohibited.**

---

---

**WARNING**                      **No operator serviceable parts inside. Refer servicing to qualified personnel. To prevent electrical shock do not remove covers.**

---

---

**CAUTION**                      Always use the three-prong ac power cord supplied with this product. Failure to ensure adequate grounding may cause product damage.

---



<b>1. Getting Started</b>	
Installing the Optional Measurement Personality . . . . .	2
Requirements . . . . .	2
Recording the License Key . . . . .	2
Installing the Licensing Key . . . . .	3
Using Install Key . . . . .	4
Installer Screen and Menu . . . . .	6
<b>2. Menu Maps and Key Descriptions</b>	
Menus . . . . .	10
Mode and Measure Menus . . . . .	10
Measurement Setup Menus . . . . .	11
Cable Fault Location . . . . .	12
<b>3. Making Measurements</b>	
Chapter Contents . . . . .	16
Making Cable Fault Measurements . . . . .	17
Purpose . . . . .	17
Calibrating the System . . . . .	17
Reading the Cable Fault Location Measurement . . . . .	21
Making Return Loss Measurements . . . . .	22
Purpose . . . . .	22
Making the measurement . . . . .	22
Example . . . . .	24
Making Loss/Gain Measurements . . . . .	29
Purpose . . . . .	29
Making the measurement . . . . .	29
Example . . . . .	31
<b>4. If You Have a Problem</b>	
What to do Next . . . . .	34
Before You Call Agilent Technologies . . . . .	36
Read the Warranty . . . . .	36
Contacting Agilent Technologies . . . . .	36



---

# **1** **Getting Started**

This chapter describes the process for installing the personality.

---

## Installing the Optional Measurement Personality

### Requirements

The tracking generator, Option 1DN or 1DQ is required to load the personality.

### Recording the License Key

The measurement personality software you have purchased with your instrument has been installed and the license key has been enabled at the factory. With any future purchase of a new personality software, you will receive a certificate that displays the unique license key number. The license key enables you to install, or reinstall, any measurement personality you have purchased.

You will want to keep a copy of your license key number in a secure location. Please enter your license key numbers in the box provided below for future reference. If you should lose your license key number, get in touch with your local Agilent Technologies service or sales office for assistance. For the location of these offices, refer to [Table 4-1 on page 37](#).

<b>Active License Key Numbers for Instrument with Serial # _____</b>
For Option _____ the license number is _____
For Option _____ the license number is _____
For Option _____ the license number is _____

You will need to use a license key number only under the following conditions:

- If you purchase an additional measurement software package.
- If the controller board is repaired or replaced.



## Installing the Licensing Key

If you are installing a new option, follow these steps to install the unique license key number for the measurement personality software that you want to install in your instrument:

1. Press **System, More, Licensing, Option**.

When you press **Option** the alpha editor will be activated. For instructions on using the alpha editor, refer to the *ESA Spectrum Analyzers User's Guide*.

2. Use the alpha editor to enter the three letter designation for the software option that you wish to install in the instrument.
3. Press **Return** when finished.
4. Press **License Key**.

When you press **License Key** the alpha editor will be activated. For instructions on using the alpha editor, refer to the *ESA Spectrum Analyzers User's Guide*.

5. Use the alpha editor to enter the 12 character licensing key number for the software option that you wish to install in the instrument.
6. Press **Return** when finished.
7. Press **Activate** to turn on the licensing key. You may now install the measurement personality option software.

## Using Install Key

You may want to install a software revision, new measurement software or reinstall measurement software, or uninstall measurement software. Before you can install software, you will need a set of installation diskettes.

If you have ordered a measurement personality, you will receive the installation disk set in the option upgrade package. If you are updating an existing, previously installed measurement option, you may order the diskettes from Agilent Technologies or create a set from the Agilent internet site [www.agilent.com/find/esa](http://www.agilent.com/find/esa).

## Creating Software Installation Disks

To create the installation disks on-line, visit the Agilent internet site [www.agilent.com/find/esa](http://www.agilent.com/find/esa). Follow the instructions provided on the internet site for downloading the current measurement personality software and creating the installation disk set. The instructions for creating the disk set will step you through the process to create a firmware disk set when you create the measurement personality software disk set. A firmware update may be needed to ensure that the firmware and the software are compatible. After you have created the disk set, follow the on-line instructions to install the firmware. After successfully installing the firmware update, proceed with the following instructions for installing the measurement personality software in your instrument.

## Installing Personality/Software Options

This procedure gives steps to install a new software option in an ESA-E Series Spectrum Analyzer using the internal floppy drive of the instrument. Screen messages display the update progress and give directions. The instrument will not need to be re-calibrated after this procedure since no changes are made to calibration or adjustment files.

If you have a problem with the installation process, refer to [“Troubleshooting the Installer” on page 5](#).

When the installer starts up, it examines the instrument to ensure that all the required software and hardware options are present. If they are not, the installer will generate an error and you will not be able to install the personality.

1. If this is the installation of new personality option software, you must enter the License Key for the new option. For instructions on entering the License Key, refer to the [“Installing the Licensing Key” on page 3](#).

When you have completed entering the license key number, continue with the next step.

2. Insert disk one of the installation disk set into the disk drive located on the right side of the ESA front panel.

3. Press **System, More, Personalities, and Install**. The instrument will then load the installer off of the floppy drive. If there is no floppy in the drive, an incorrect disk is inserted, or there is no installer on the disk, the error “No install disk present in disk drive” will be shown.

Once the instrument has loaded the installer, the screen will change to the installer screen and the **Install Pers.** menu will be shown. For more information on the installer screen and menu, refer to “[Installer Screen and Menu](#)” on page 6.

4. When the installer first starts up, it will show a popup message. Select **Verify Disks**.

Once the installer has begun installing a personality, any error will cause the whole personality, including a previously installed version, to be removed from the instrument. Because of this, it is very important that you verify the disks prior to installing them. If any of the disks or files are bad, you will not be able to use the personality until you obtain a new installation disk set and run the install using them.

5. When prompted, insert the next disk and press **Verify Disks** again.

When Verify Disks is running, the **Install Now** and **Exit Install** keys will be grayed out.

6. When the verification is complete, press **Install Now** and the installation of the personality will begin. Some of the disks may take only a short time to load or be skipped entirely, while others can take up to about 30 minutes to load.

When installer is running, the **Verify Disks** and **Exit Install** keys will be grayed out.

7. When prompted, insert the next disk and press **Install Now**.

8. Once the installation is complete, press **Exit Install**.

### Troubleshooting the Installer

If the installation process stalls or fails in another way, follow these steps to resolve your problem.

1. If the instrument stops the update process before all the disks are loaded proceed as follows:
  - a. Press **Exit Install** to abort the process.
  - b. Return to step 2 under “[Installing Personality/Software Options](#)” and start the installation process again.

## Getting Started

### Installing the Optional Measurement Personality

- If the instrument fails after repeating the installation procedure, get in touch with your nearest Agilent Technologies sales and service office listed in [Table 4-1 on page 37](#) for assistance. Please provide the following information:

Model Number:

Serial Number:

State that you are having trouble installing a software option update.

## Installer Screen and Menu

The top portion of the install screen is a table in which the files that are about to be installed are listed. The bottom portion of the screen contains information needed to track the progress of the install.

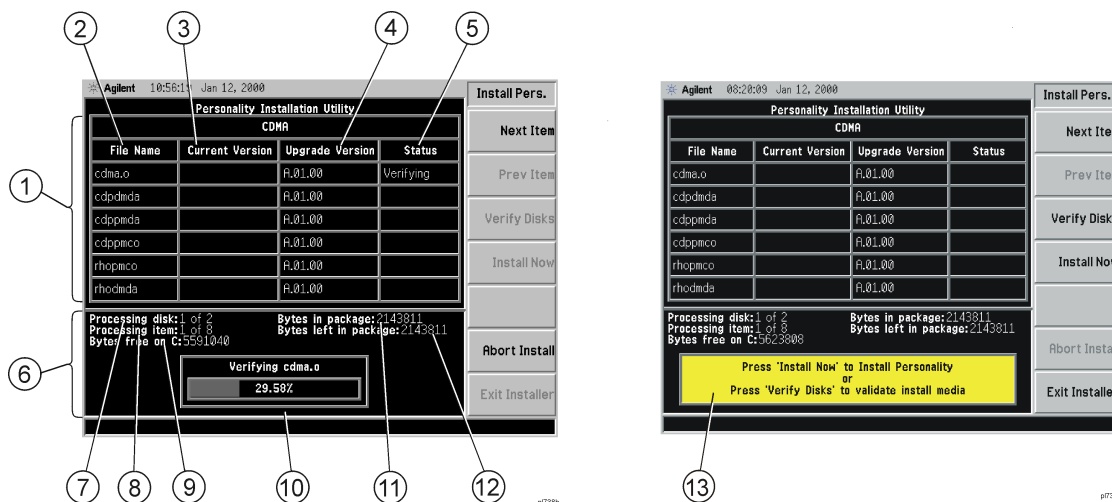

- File Table** displays the files to be installed and various file information. If there are more than six files, **Next Item** and **Prev Item** allow you to scroll the table to view additional items.
- File Name** displays the name of the files on the installation disk.
- Current Version** displays the version of the file that is currently installed in the instrument. (This field will be blank if this file is not currently installed in the instrument or if the file is a data file that has no version.)
- Upgrade Version** shows the version of the file on the install disk. This is the version of the file that will replace the currently installed version.
- Status** is updated to reflect what the installer is doing to the current file. The valid messages seen in this column are listed in [Table 1-1 on page 7](#).
- Data Field** contains a status bar and various status information.
- Processing disk** shows the disk that is currently being read.

- 8 **Processing item** shows the file that is being processed by item number.
- 9 **Bytes free on C** is the number of bytes currently free on the instrument C: drive.
- 10 **Status Bar** contains a status bar that runs from 0 to 100% and tracks the progress of the current step. A message line displays the step that is currently being executed.
- 11 **Bytes in package** lists the number of bytes in the install package file.
- 12 **Bytes left in package** lists the number of bytes left to be read.
- 13 Message and error popup window that displays over the status bar. Information in this box will prompt you for action required to proceed to the next phase of the installation. It may also inform you of errors in the installation process and may prompt you for action required to correct the problem.

**Table 1-1**      **Installer Status Messages**

Failed	This means that something has gone wrong while processing this item. It is a fatal error and the installation can not be completed. The installer will try to get the system back to a good state which may entail completely removing the currently installed personality.
Loading	The file is currently being copied from the install media to the instrument's file system.
Verifying	This may mean one of two things: <ol style="list-style-type: none"> <li>1. If "Verify Disks" was pressed then Verifying means that the installer is currently reading the install media and comparing the known checksums to ensure the data is good.</li> <li>2. If "Install Now" was pressed, then Verifying means that the installer is reading what was just loaded to ensure the checksum is correct.</li> </ol>
Loaded	This means that the data has been placed on the instrument disk but has not yet been registered with the firmware.
Installed	This means that the data has been loaded into the instrument and registered. The install for this file is complete.
Skipping	This means that the installer has determined that this file does not need to be loaded into the instrument.

Getting Started  
Installing the Optional Measurement Personality

---

## **2      Menu Maps and Key Descriptions**

This chapter provides a visual representation of the front panel keys and their associated menu keys.

# Menus

## Mode and Measure Menus

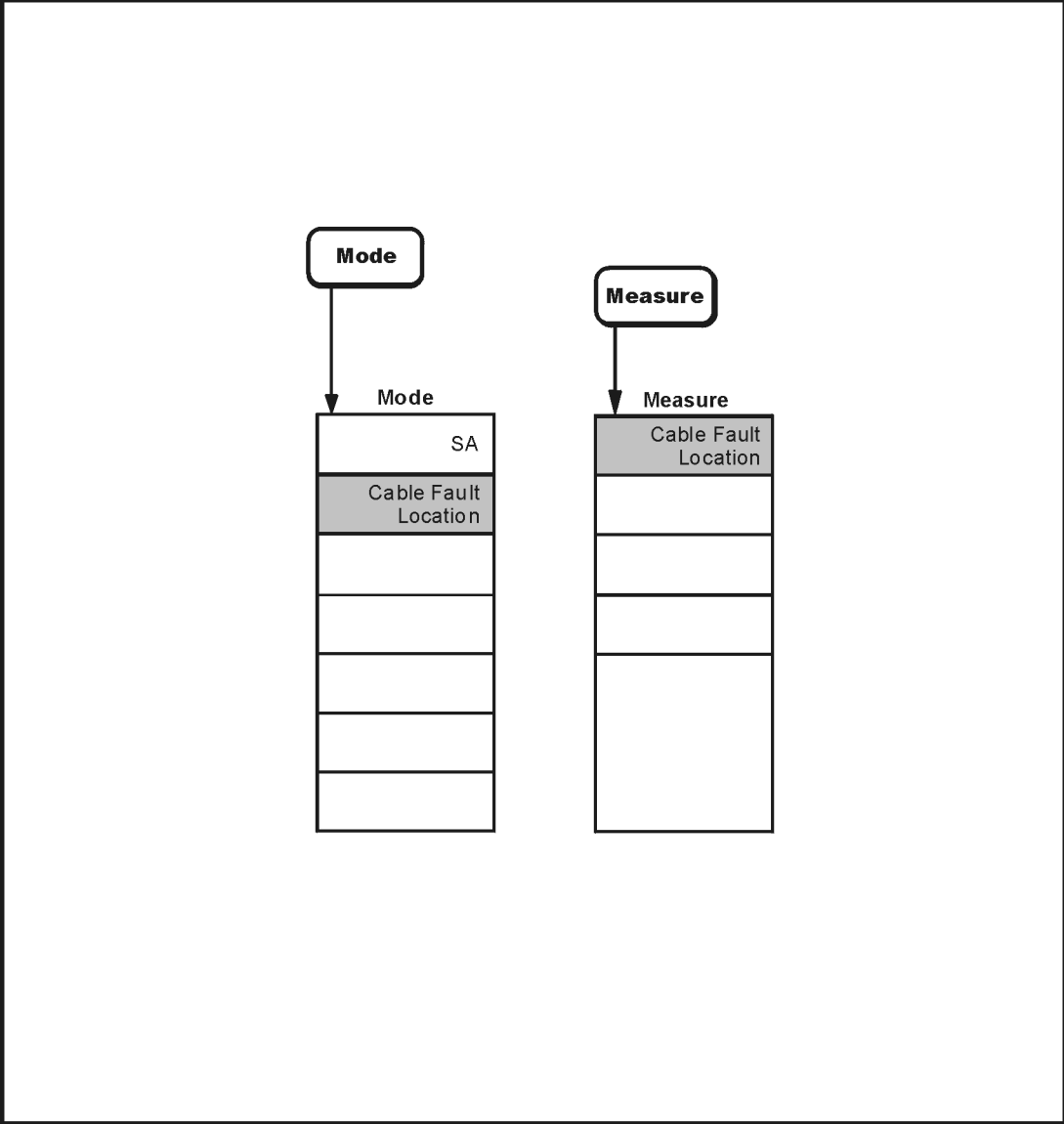

pl723c



## Measurement Setup Menus

### Cable Fault Measurement Setup Menu

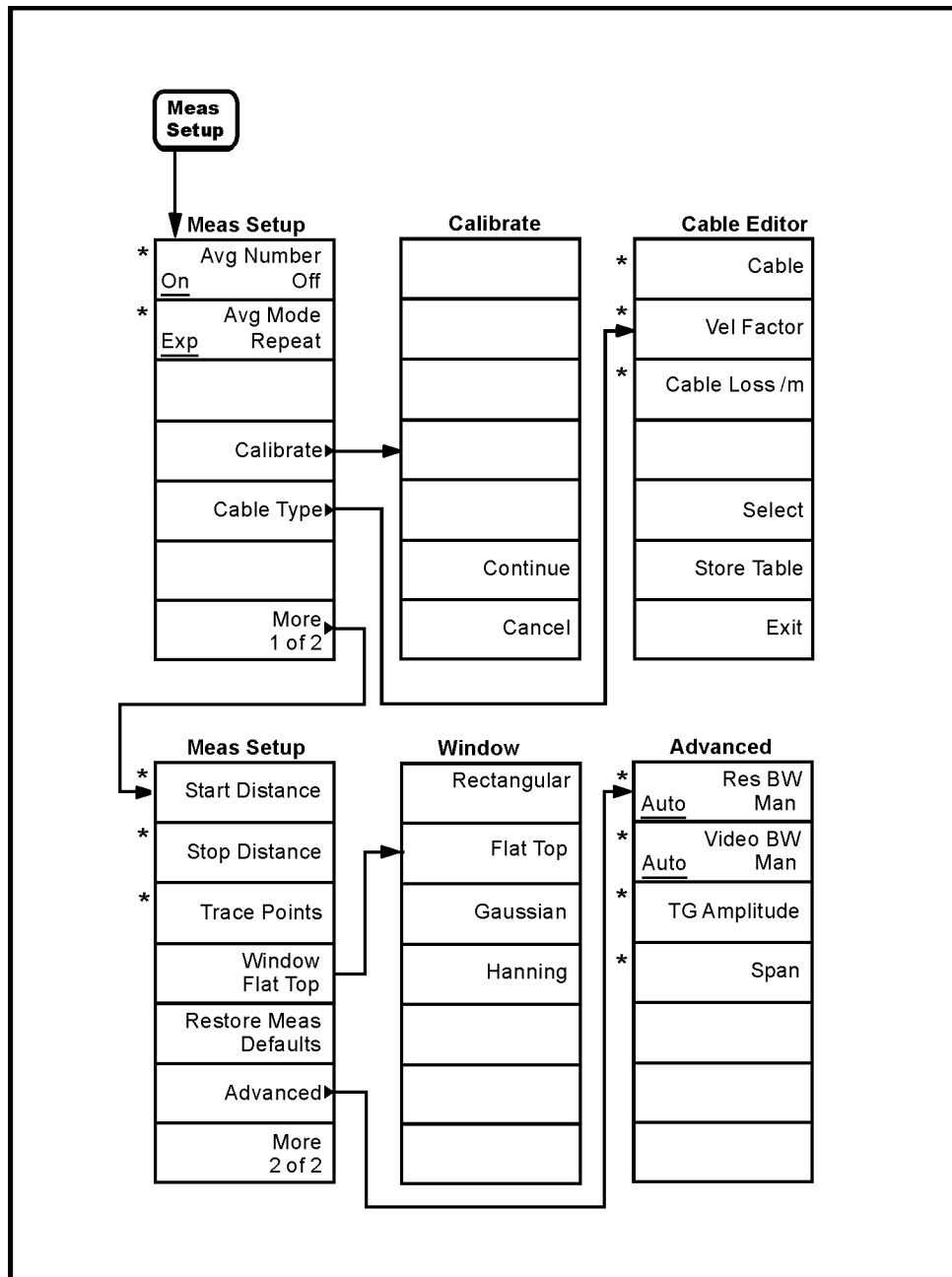

\* An active function that allows data entry.

p1724c

## Cable Fault Location

To access the keys for setting up a cable fault location measurement, press **MEASURE**, **Cable Fault Location**, and then the front panel **Meas Setup** key.

### Avg Number

Used to specify the number of data acquisitions that will be averaged. After the specified number of average counts, the averaging mode (terminal control) setting determines the averaging action.

**On**                      Sets measurement averaging on.

**Off**                      Sets measurement averaging off.

Default values are 10 and Off, and range values are 1 to 1000.

### Avg Mode

Used to select the type of termination control used for the averaging function. This determines the averaging action after the specified number of data acquisitions (average count) is reached.

**Exponential**        After the average count is reached, each successive data acquisition is exponentially weighted and combined with the existing average.

**Repeat**                After reaching the average count, the averaging is reset and a new average is started.

The default value is exponential.

### Calibrate

Used to calibrate the spectrum analyzer, removing any errors introduced by the cabling and components of the test setup before making the measurement.

### Cable Type

Used to select the type of cable being tested. Provides access to the Cable Editor form, displaying a table listing relevant cable types, plus the following keys:

**Cable**                      Used to select an entry in the cable type table. Accepts numeric values.

**Vel Factor**              The velocity factor for the cable type selected. The field's numeric value represents a proportion of the speed of light. The value can be edited and saved using the **Store Table** key.

**Cable Loss/m**          The amount of signal lost per meter for the cable type selected, expressed in dB. The value can be edited and saved using the **Store Table** key.

**Store Table**              Used to save any changes made to the **Cable**, **Vel Factor** or **Cable Loss/m** parameters.

### Start Distance

Used to define the start position of the range over which faults will be measured. This allows the user to zoom in on certain faults.

The default value is 0 m.

**Stop Distance** Used to define the stop position of the range over which faults will be measured. The smaller the value of this field, the more closely faults can be viewed. Therefore, the value should be set as close as possible to the length of the test apparatus.

The default value is 20 m.

**Trace Points** The number of trace points used in the measurement. Changing the number of trace points affects the minimum and maximum measurable distances. As a general rule, the longer the cable, the more trace points you should use. It is possible to select up to 8192 trace points but due to the computationally-intensive FFT, the higher the value, the slower the measurement becomes. To ensure the fastest possible speed, use a value that is a power of 2—for example 512, 1024 and so on.

**Window** Used to select the FFT windowing function to be used. The cable fault measurement uses an FFT to convert the analyzer frequency trace into a distance trace. To get the best possible results from the FFT, it is important to apply the most suitable windowing function to the frequency trace before performing the FFT. Possible values are Rectangular, Flat Top, Gaussian, and Hanning. The default value is Flat Top. The following table describes these values.

Function	Description	Max Side-Lobe Level	Side-Lobe Roll Off	Max Main
Rectangular	Results in no windowing.	-13.3 dB	20 dB/decade	-3.92 dB
Flat Top (default)	The five term flat-top window. A good window to use when making amplitude measurements of relatively pure tones.	-95.1 dB		+/-0.00208 dB
Gaussian	A five term cosine window that resembles a Gaussian window.	-125 dB		-0.68 dB
Hanning	Has a good frequency resolution and reasonably good side-lobe roll-off, but poor main-lobe flatness and relatively large side-lobe peaks.	-31.5 dB	60 dB/decade	-1.42 dB

**Restore Meas Defaults** Restores all **Meas Setup** parameter values for the current measurement to their factory defaults.

**Advanced** Provides access to the following advanced measurement parameter settings:

**Res BW** Used to set the resolution bandwidth used for the measurement and to define whether it is automatic or manual. Default values are 3 MHz and Auto.

**Cable Fault Location**

<b>Video BW</b>	Used to set the video bandwidth used for the measurement and to define whether it is automatic or manual. The default values are 3 MHz and Auto.
<b>TG Amplitude</b>	Used to set the power level of the internal source. The default output level is -10 dBm.
<b>Span</b>	Changes the frequency span used when acquiring the trace data prior to the FFT. This, in conjunction with Trace Points and Velocity Factor, has a direct effect on the maximum distance that can be measured and the subsequent span resolution. Span is provided for use in conjunction with <b>Center Freq</b> , under <b>FREQUENCY</b> , when measuring DUTs that have limited or restricted bandpass characteristics.

---

## **3 Making Measurements**

## Chapter Contents

This chapter details how to make cable, antenna, and device under test (DUT) measurements. The following measurements are described:

- Cable fault location; performed in cable fault location mode.
- Return loss (VSWR); performed in SA mode.
- Loss/gain; Transmit band low-noise amplifier (LNA) gain and flatness/receive band combiner loss and flatness performed in SA mode.

The return loss (VSWR) and loss/gain measurements are not “one button” measurements. All steps required to run them are fully detailed in this chapter.

## Making Cable Fault Measurements

### Purpose

A cable fault location measurement displays the reflected signal of a transmission line as a function of the distance down the line. This complements the return loss measurement described in the following section: if a cable under test fails a return loss measurement, a cable fault location measurement can be used to identify the location of the fault. The measurement is particularly useful when a transceiver and antenna are connected by a long length of cable.

### Calibrating the System

For the following procedure, use the appropriate 50 ohm or 75 ohm cables and accessories listed in [Table 3-1](#).

A return loss measurement requires the use of a power divider.

**Table 3-1**

**Cables and Accessories**

Cable/Accessory	Quantity	50 Ohm Setup Part Number	75 Ohm Setup Part Number
Coaxial cable	2	8121-0101	5062-6452
Power divider	1	11636A	0955-0752
Coaxial load	1	909A Option 012	909E
6 dB Attenuator (50 ohm only)	2	0955-0826	n/a
Adapter 75 ohm N(f) to 75 ohm BNC(f) (75 ohm only)	1	n/a	1250-1536
Adapter 75 ohm N(m) to 75 ohm BNC(f) (75 ohm only)	1	n/a	1250-1535

1. Enter cable fault location mode and access the measurement.
  - a. Press the **Mode** front panel key.
  - b. Press the **Cable Fault Location** menu key.
  - c. Connect the equipment as prompted by the dialog box and illustrated in [Figure 3-1](#).

**Figure 3-1** Calibrating for Cable Fault Location

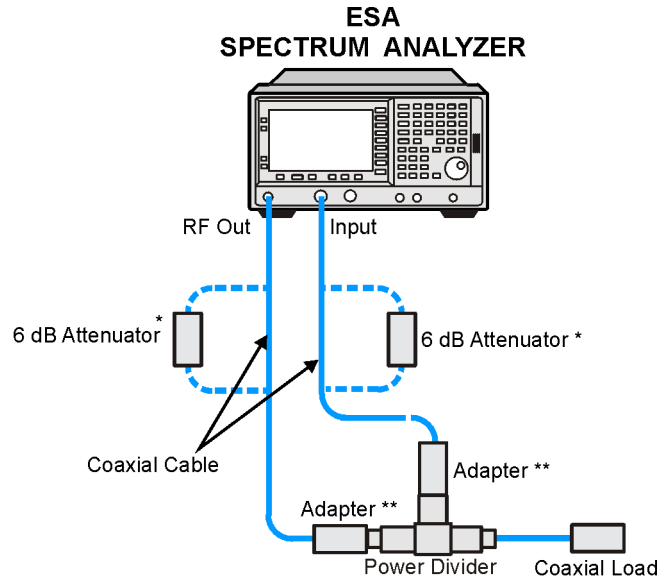

bl726a

\* 50 ohm only. The 6 dB attenuators may be used to improve impedance matching.

\*\* 75 ohm only.

---

**NOTE**

The distance-to-fault accessory kit, Option B7K, has all the 50 ohm accessories required to make these measurements. [Table 3-1 on page 17](#) lists the cables and accessories required for 50 ohm and 75 ohm measurements.

---

2. Configure the spectrum analyzer for the appropriate cable type.
  - a. Press the **Cable Type** menu key, and observe the Cable Type Selection Screen as shown in [Figure 3-2](#).
  - b. Page through available cable types using the **Tab**, **RPG**, or **Step** keys.
  - c. Press the **Select** menu key to select the appropriate cable type.
  - d. If you don't see your particular cable type listed, you can modify one of the "Custom" cables at the end of the cable type list. You will need to know the Velocity Factor and Cable Loss per Metre data for your cable:
    1. Select one of the unused Custom cables.
    2. Press **Vel Factor**
    3. Key in the value
    4. Press **Enter**
    5. Press **Cable Loss /m**
    6. Key in the value (dB).
    7. Press **Enter**.
    8. Press **Store Table** to save the changes.



Figure 3-2 Cable Type Selection Screen

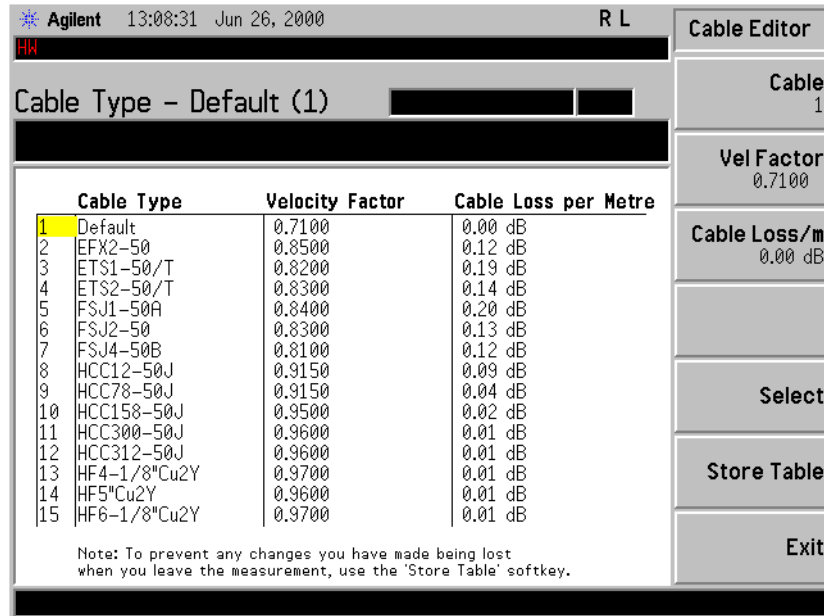

3. Set up a maximum range value just greater than the length of the cable to be tested:
  - a. Press the **Stop Distance** menu key.
  - b. Enter the appropriate value using the numeric key pad.
4. If required, set up a start distance offset to be used when displaying the trace and calculating distances:
  - a. Press the **Start Distance** menu key.
  - b. Enter the appropriate value using the numeric key pad.

**NOTE**

The above steps may cause the trace-points parameter to be changed. To prevent this from happening, change this parameter to manual before attempting steps 2 through 4. If you choose to override this parameter, the resultant trace may appear discontinuous.

5. Calibrate the spectrum analyzer.

Calibration removes any errors introduced by the cabling and components of the test setup before making the measurement.

**NOTE**

Press the **Esc** front panel key to cancel this procedure at any stage.

- a. Disconnect the cable to be tested.
- b. Press the **Meas Setup** front-panel key.

Making Measurements  
Making Cable Fault Measurements

- c. Press **Calibrate**.  
For a 50 ohm setup, connect a load to the analyzer via the power divider as prompted. See [Figure 3-1](#). For a 75 ohm setup, leave the output port of the power splitter open.
- d. Press **Continue**. Your setup is now calibrated.  
Connect a DUT (device under test).
- e. Press **Continue**.

**Figure 3-3** Cable Fault Location Measurement Setup

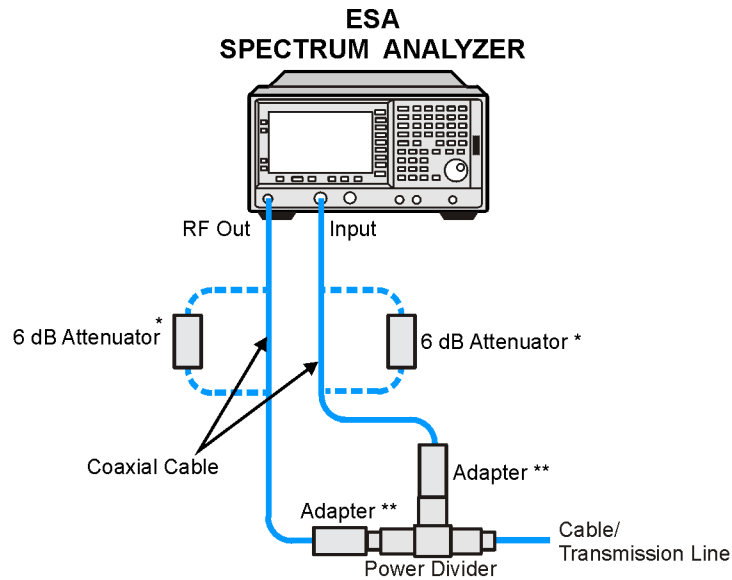

bl727a

\* 50 ohm only. The 6 dB attenuators may be used to improve impedance matching.

\*\* 75 ohm only.

**NOTE**

The distance-to-fault accessory kit, Option B7K, has all the 50 ohm accessories required to make these measurements. [Table 3-1 on page 17](#) lists the cables and accessories required for 50 ohm and 75 ohm measurements.

## Reading the Cable Fault Location Measurement

Read the measurement and save it if required. The result is shown on the screen. Press the Marker front panel key to move the marker (1) to the fault(s) of interest. An example is shown in [Figure 3-4](#).

1. Connect the cable under test to the power divider. The measurement will start automatically.
2. Using the rotary pulse generator (RPG) knob, position the marker (1) to the fault of interest. Refer to [Figure 3-4](#).
3. Interpretation of the display:
  - Marker (1)
  - Resolution (2)
  - Distance-to-fault in meters (3)

**Figure 3-4** Example Cable Fault Location Measurement Screen

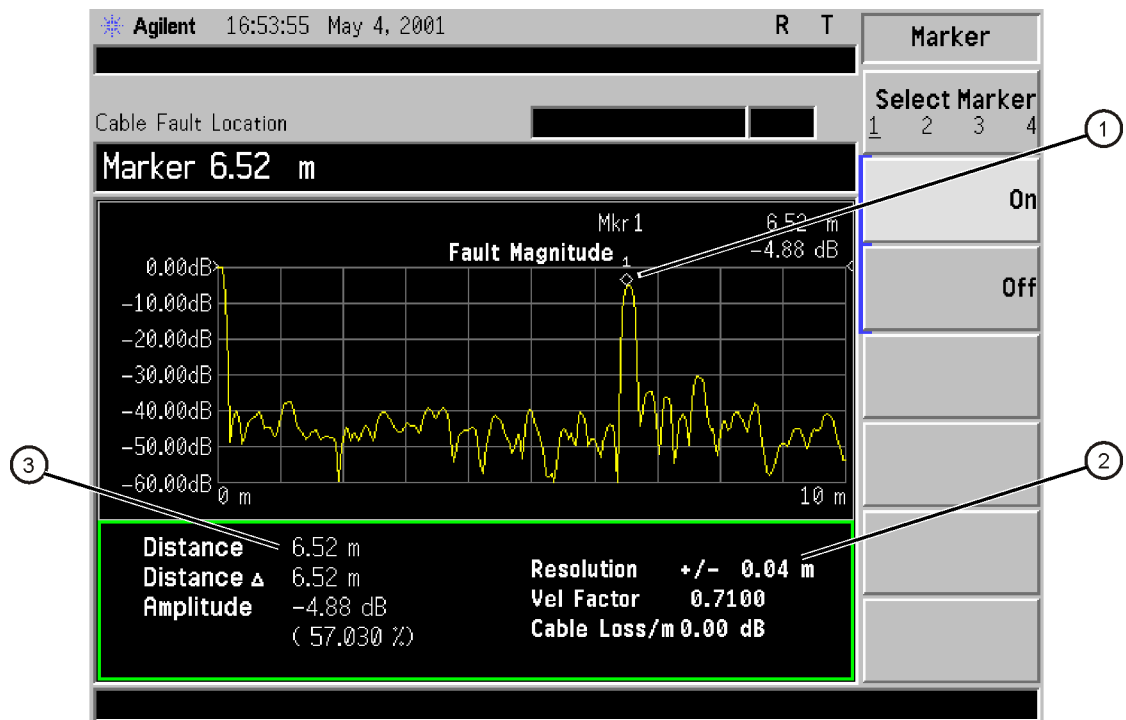

bl731a

---

## Making Return Loss Measurements

### Purpose

Some of the energy incident upon a device can be reflected back towards the source. A return loss measurement quantifies this reflected energy. Return loss is used to determine the health of an antenna system and its associated cabling by measuring the amount of transmitted power reflected back from the antenna system and therefore not passed over the air interface to the mobile user.

Cables and antennae are often subjected to harsh weather conditions resulting in a performance which deteriorates over time, leading to an eventual failure. By monitoring return loss over time, cable and antennae performance can be monitored and preventive action taken when required.

### Making the measurement

A return loss measurement requires the use of a signal separation device such as a directional coupler or bridge in addition to the device being tested for return loss. The spectrum analyzer must be in spectrum analyzer mode for this measurement.

### Procedure

For the following procedure, use the appropriate 50 ohm or 75 ohm cables and accessories listed in [Table 3-2](#).

**Table 3-2**

**Cables and Accessories**

Cable/Accessory	Quantity	50 Ohm Setup Part Number	75 Ohm Setup Part Number
Coaxial cable	2	8121-0101	5062-6452
RF Bridge	1	86205A	86207A
Coaxial load	1	909A Option 012	909E
Coaxial short (50 ohm only)	1	11512A	n/a
6 dB Attenuator (50 ohm only)	2	0955-0826	n/a
Adapter 75 ohm N(f) to 75 ohm BNC(f) (75 ohm only)	2	n/a	1250-1536

1. Connect the tracking generator, signal separation device, device being measured and the spectrum analyzer input as shown in [Figure 3-5](#).

**Figure 3-5**      **Calibrating for Return Loss**

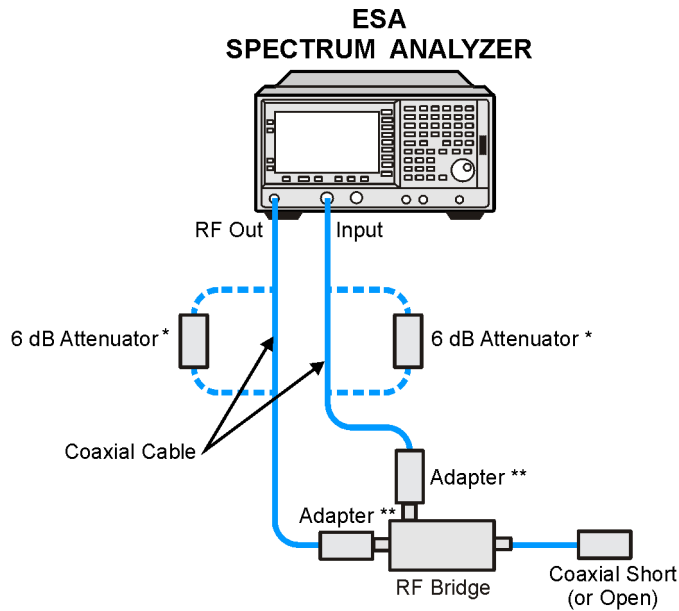

b1728a

\* 50 ohm only. The 6 dB attenuators may be used to improve impedance matching.

\*\* 75 ohm only.

**NOTE**

The distance-to-fault accessory kit, Option B7K, has all the 50 ohm accessories required to make these measurements. [Table 3-2 on page 22](#) lists the cables and accessories required for 50 ohm and 75 ohm measurements.

2. Turn on the tracking generator.
  - a. Press the **Source** front panel key.
  - b. Press the **Amplitude** menu key so that the tracking generator is turned on.
  - c. Set an amplitude level appropriate for the device under test. The default value =  $-10$  dBm. 0 dBm may be used for systems with higher loss.
3. Adjust the spectrum analyzer control settings (for example frequency, resolution bandwidth, sweep time and input attenuation) as appropriate for the signal separation device and device being tested.
4. Establish a 0 dB reference trace for normalizing the measured data.
  - a. Remove the device to be measured and replace it with a short or open.
  - b. Press the **View/Trace** front panel key.
  - c. Press the **More** menu key.
  - d. Press the **Normalize** menu key, and normalize **On**.

5. Make the measurement.
  - a. Reconnect the device to be measured to the signal separation device.
  - b. Read the measurement and save it if required.

### Example

The following example measures the return loss of a bandpass filter (BPF).

1. Adjust the spectrum analyzer control settings.

With the BPF in the measurement path, adjust the spectrum analyzer control settings for the correct frequency coverage, resolution bandwidth, input attenuation and source power.

Having adjusted the control settings, do not alter them during the course of the measurement.

To obtain a faster sweep, change the coupling from normal spectrum analyzer mode to stimulus response mode by pressing the **Sweep** front panel key and **Swp Coupling SR SA** menu key until **SR** is underlined.

2. Establish a 0 dB reference trace for normalizing the measured data.

Normalization removes any frequency-response errors introduced by the components of the test setup before making the measurement. It is performed by removing the device to be tested and measuring a short or open. As neither can dissipate the energy of the incident signal—100% reflection takes place, and the wave is reflected back from the short or open—to the spectrum analyzer where its value is displayed:

- a. Remove the BPF and connect a short in its place as shown in the figure.
- b. Press the **View/Trace** front panel key.
- c. Press the **More** menu key.
- d. Press the **Normalize** menu key, **Store Ref (1 - 3)** and normalize **On**.

This procedure establishes a 0 dB reference trace which is stored in the ESA spectrum analyzer. It is then used to normalize the measured data automatically by subtracting the short circuit calibration from the measurement obtained with the device.

**Figure 3-6** Return Loss Measurement Setup

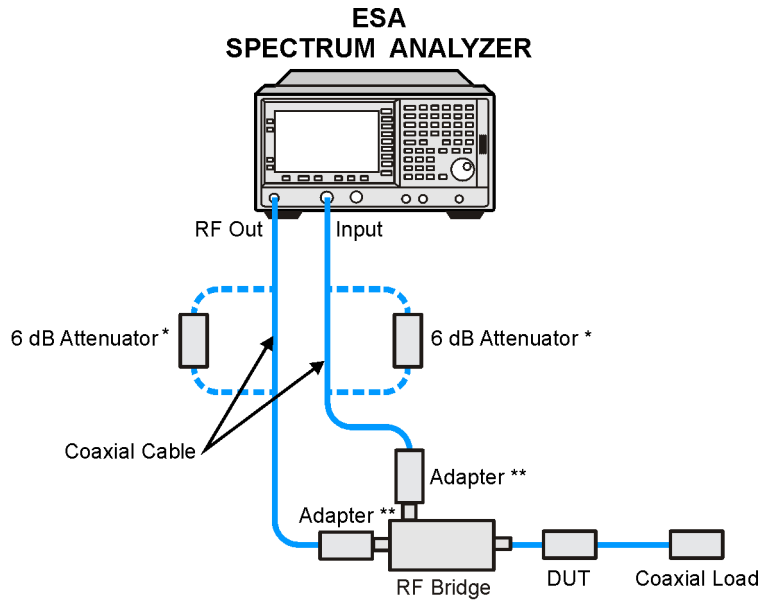

b1729a

\* 50 ohm only. The 6 dB attenuators may be used to improve impedance matching.

\*\* 75 ohm only.

---

**NOTE**

The coaxial load shown in [Figure 3-6](#) must be used if the DUT is a two-port device.

---

3. Make the measurement.
  - a. Reconnect the device in place of the short/open.
  - b. Read the measurement and save it if required.  
The return loss of the device is displayed on the screen. Use the marker to evaluate the result and save the trace if required.
  - c. An example is shown in [Figure 3-7](#).

Figure 3-7 Example Return Loss Measurement for a Bandpass Filter

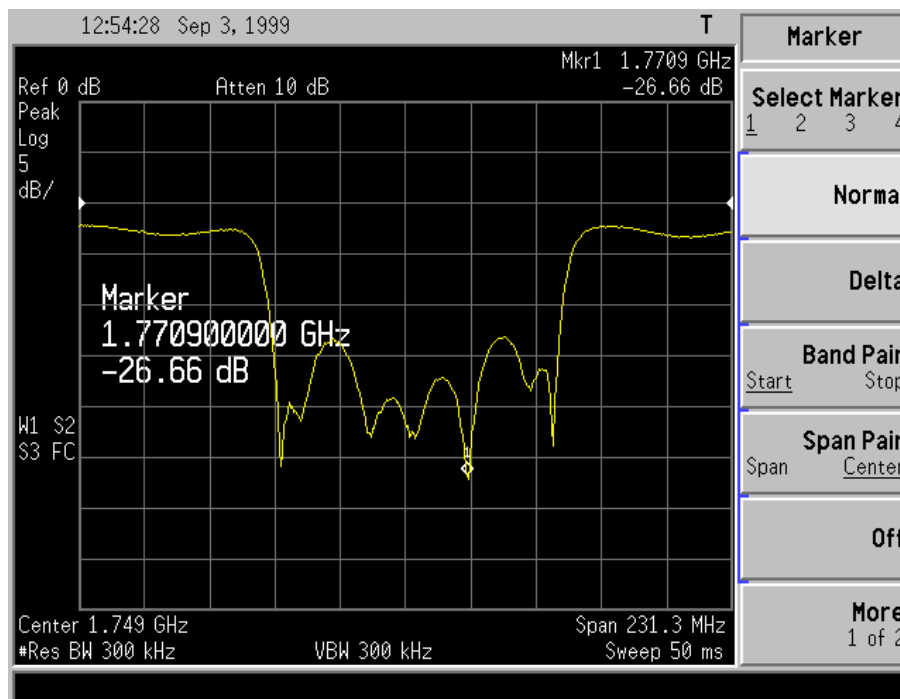



### Converting Return Loss to VSWR

Return loss can be expressed as a voltage standing wave ratio (VSWR) value using the following table or formula:

**Table 3-3                  Power to VSWR Conversion**

Return Loss (dB)	VSWR	Return Loss (dB)	VSWR	Return Loss (dB)	VSWR	Return Loss (dB)	VSWR	Return Loss (dB)	VSWR
4.0	4.42	14.0	1.50	18.0	1.29	28.0	1.08	38.0	1.03
6.0	3.01	14.2	1.48	18.5	1.27	28.5	1.08	38.5	1.02
8.0	2.32	14.4	1.47	19.0	1.25	29.0	1.07	39.0	1.02
10.0	1.92	14.6	1.46	19.5	1.24	29.5	1.07	39.5	1.02
10.5	1.85	14.8	1.44	20.0	1.22	30.0	1.07	40.0	1.02
11.0	1.78	15.0	1.43	20.5	1.21	30.5	1.06	40.5	1.02
11.2	1.76	15.2	1.42	21.0	1.20	31.0	1.06	41.0	1.02
11.4	1.74	15.4	1.41	21.5	1.18	31.5	1.05	41.5	1.02
11.6	1.71	15.6	1.40	22.0	1.17	32.0	1.05	42.0	1.02
11.8	1.69	15.8	1.39	22.5	1.16	32.5	1.05	42.5	1.02
12.0	1.67	16.0	1.38	23.0	1.15	33.0	1.05	43.0	1.01
12.2	1.65	16.2	1.37	23.5	1.14	33.5	1.04	43.5	1.01
12.4	1.63	16.4	1.36	24.0	1.13	34.0	1.04	44.0	1.01
12.6	1.61	16.6	1.35	24.5	1.13	34.5	1.04	44.5	1.01
12.8	1.59	16.8	1.34	25.0	1.12	35.0	1.04	45.0	1.01
13.0	1.58	17.0	1.33	25.5	1.11	35.5	1.03	45.5	1.01
13.2	1.56	17.2	1.32	26.0	1.11	36.0	1.03	46.0	1.01
13.4	1.54	17.4	1.31	26.5	1.10	36.5	1.03	46.5	1.01
13.6	1.53	17.6	1.30	27.0	1.09	37.0	1.03	47.0	1.01
13.8	1.51	17.8	1.30	27.5	1.09	37.5	1.03	47.5	1.01

Making Measurements  
Making Return Loss Measurements

$$\text{VSWR} = \frac{1 + 10^{\frac{-\text{RL}}{20}}}{1 - 10^{\frac{-\text{RL}}{20}}}$$

Where: RL is the measured return loss value.

VSWR is sometimes stated as a ratio. For example: 1.2:1 “one point two to one” VSWR. The first number is the VSWR value taken from the table or calculated using the formula. The second number is always 1.

## Making Loss/Gain Measurements

### Purpose

Loss/gain measurements are used to verify the performance of devices or components as illustrated by the following examples:

- A loss measurement can be used to test the performance of a base station's cables. Lower than expected base station power measurements could be caused by faulty cables. A cable's role in the problem can be determined by measuring the loss of the cable and comparing the result to the expected value.
- A gain measurement can be used to test the performance of an amplifier. A lower than expected gain measurement could indicate a fault with the amplifier.

### Making the measurement

The spectrum analyzer must be in spectrum analyzer mode for this measurement.

For the following procedure, use the appropriate 50 ohm or 75 ohm cables and accessories listed in [Table 3-4](#).

**Table 3-4**

**Cables and Accessories**

Cable/Accessory	Quantity	50 Ohm Setup Part Number	75 Ohm Setup Part Number
Coaxial cable	2	8121-0101	5062-6452

1. Connect the tracking generator to the device input and the device output to the input of the spectrum analyzer as shown in [Figure 3-8](#).

**Figure 3-8** Loss/Gain Measurement Setup

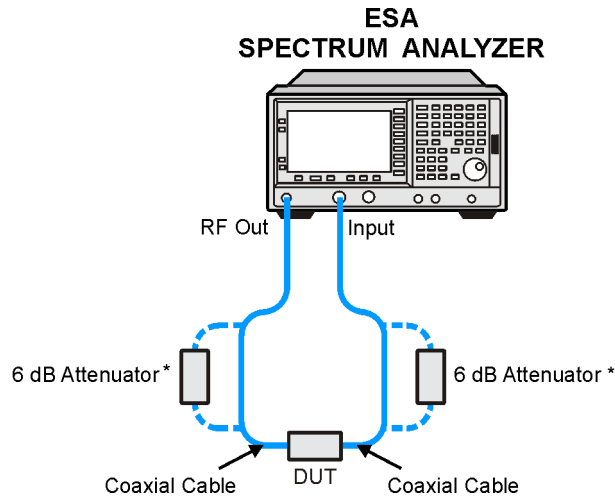

bl730a

\* 50 ohm only. The 6 dB attenuators may be used to improve impedance matching.

2. Turn on the tracking generator.
  - a. Press the **Source** front panel key.
  - b. Press the **Amplitude** menu key so that the tracking generator is turned on.
  - c. Set an amplitude level appropriate for the device under test.
3. Adjust the spectrum analyzer control settings (for example frequency, resolution bandwidth, sweep time and input attenuation) as appropriate for the device being tested.
4. Establish a 0 dB reference trace for normalizing the measured data.
  - a. Remove the device from the measurement path.
  - b. Press the **View/Trace** front panel key.
  - c. Press the **More** menu key.
  - d. Press the **Normalize** menu key, **Store Ref (1 - 3)** and normalize **On**.
5. Make the measurement.
  - a. Reconnect the device.
  - b. Reconnect the tracking generator RF output to the device input and the device output to the spectrum analyzer input as shown in [Figure 3-8](#).
  - c. Read the measurement and save it if required.

## Example

The following example measures the gain/loss of a bandpass filter (BPF).

1. Adjust the spectrum analyzer control settings.

With the BPF in the measurement path, adjust the spectrum analyzer control settings for the specific type of measurement to be made. For example:

- If making a bandpass-ripple measurement, the spectrum analyzer requires a narrow span and typically < 10 dB per vertical division to get more resolution on the display.
- If making a stop-band attenuation measurement, the spectrum analyzer requires a wide span and a narrow RBW filter.

Having adjusted the control settings, do not alter them during the course of the measurement.

To obtain a faster sweep, change the coupling from normal spectrum analyzer mode to stimulus response mode by pressing the **Sweep** front panel key and **Swp Coupling SR SA** menu key until SR is underlined. Note that the limitation on sweep speed is typically determined by the device and care must be taken to allow the device sufficient time to respond to the signal being passed through it. If the auto stimulus-response-mode sweep is too fast, slow it down until no changes in amplitude occur on the trace.

2. Establish a 0 dB reference trace for normalizing the measured data.

Normalization removes any frequency-response errors introduced by the components of the test setup before making the measurement. It is performed by removing the device and measuring a 'thru' from the source directly to the receiver. This establishes a 0 dB reference trace which is stored in the spectrum analyzer and then used to normalize the measured data:

- a. Remove the BPF and connect the tracking generator output directly to the spectrum analyzer input using the same test cables to be used when making the measurement. Use a thru adaptor to connect the test cables if necessary.
- b. Press the **View/Trace** front panel key.
- c. Press the **More** menu key.
- d. Press the **Normalize** menu key, **Store Ref (1 - 3)** and normalize **On**.

This procedure automatically subtracts the measured 'thru' level from an ideal 'thru' (a flat reference line) and stores it. This reference is then used to normalize the measured signal where:

$$\text{normalized signal} = \text{measured signal} - \text{error}$$

With the device disconnected, the displayed trace is then flat, or normalized.

The normalized trace can be moved to a different position on the display by pressing the **Norm Ref Posn** menu key. This may be useful if the device to be tested has positive gain, such as an amplifier.

Making Measurements  
Making Loss/Gain Measurements

3. Make the measurement.
  - a. Reconnect the tracking generator to the BPF input and the BPF output to the spectrum analyzer.
  - b. Read the measurement and save it if required.  
Use the marker to evaluate the result and save the trace if required.
  - c. An example is shown in [Figure 3-9](#).

**Figure 3-9** Example Loss/Gain Measurement for a Bandpass Filter

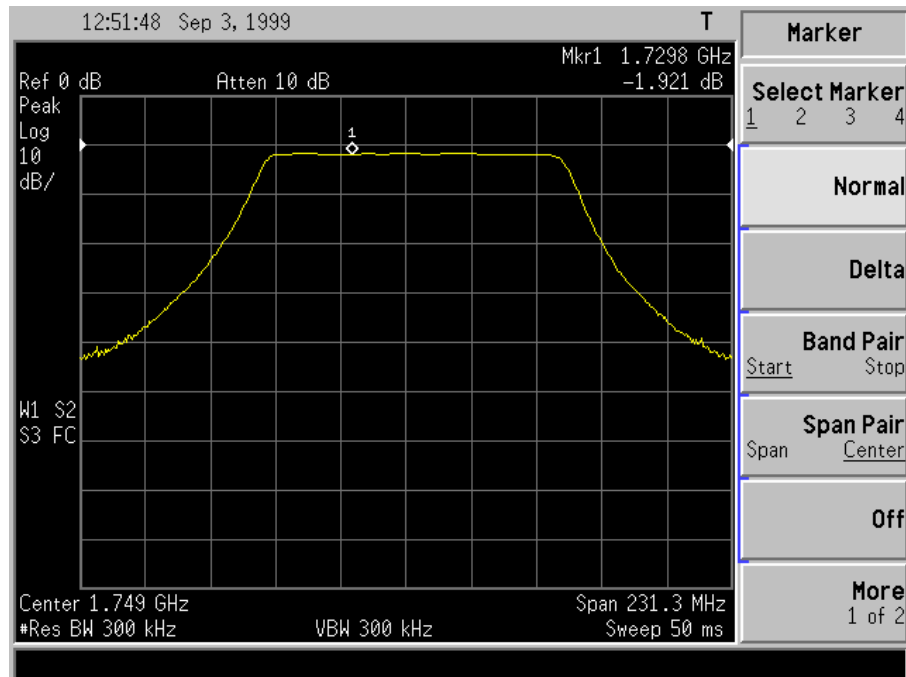



## What to do Next

Your analyzer is built to provide dependable service. However, Agilent Technologies worldwide sales and service organization is ready to provide the support if you:

- Experience a problem.
- Desire additional information.
- Wish to order parts, options, or accessories.

In general, a problem can be caused by a hardware failure, a software error, or a user error. Follow these general steps to determine the cause and to resolve the problem.

1. Refer to the user documentation to verify operation of the spectrum analyzer.
2. If the problem is a hardware problem, you have two options:
  - a. Repair it yourself, or
  - b. Return the analyzer to Agilent Technologies for repair. If the analyzer is still under warranty or is covered by an Agilent Technologies maintenance contract, it will be repaired under the terms of the warranty or plan (the warranty is at the front of this manual).

If the analyzer is no longer under warranty or is not covered by an Agilent Technologies maintenance plan, Agilent Technologies will notify you of the cost of the repair after examining the instrument. See “[Contacting Agilent Technologies](#)” for more information.



3. If the problem is a software problem, you have two options:
  - a. Reinstall the firmware and/or the measurement personality.
  - b. Return the analyzer to Agilent Technologies for repair. If the analyzer is still under warranty or is covered by an Agilent Technologies maintenance contract, it will be repaired under the terms of the warranty or plan (the warranty is at the front of this manual).

If the analyzer is no longer under warranty or is not covered by an Agilent Technologies maintenance plan, Agilent Technologies will notify you of the cost of the repair after examining the instrument. See [“Contacting Agilent Technologies”](#) for more information.

## Before You Call Agilent Technologies

### Read the Warranty

The warranty for your analyzer is at the front of this manual. Please read it and become familiar with its terms.

If your analyzer is covered by a separate maintenance agreement, please be familiar with its terms.

### Contacting Agilent Technologies

Agilent Technologies has sales and service offices around the world to provide you with complete support for your analyzer. To obtain servicing information or to order replacement parts, get in touch with the nearest Agilent Technologies sales and service office listed in

[Table 4-1](#). In any correspondence or telephone conversations, refer to your analyzer by its product number, full serial number, and firmware revision. (Press **System**, **More**, **Show System**, and the product number, serial number, and firmware revision information will be displayed on your analyzer screen.) A serial number label is also attached to the rear panel of the analyzer.

Table 4-1

**Contacting Agilent Technologies**

**Online assistance:** [www.agilent.com/find/assist](http://www.agilent.com/find/assist)

<b>United States</b> (tel) 1 800 452 4844	<b>Japan</b> (tel) (+81) 426 56 7832 (fax) (+81) 426 56 7840	<b>New Zealand</b> (tel) 0 800 738 378 (fax) (+64) 4 495 8950	<b>Europe</b> (tel) (+31) 20 547 2323 (fax) (+31) 20 547 2390
<b>Canada</b> (tel) 1 877 894 4414 (fax) (905) 282 6495	<b>Latin America</b> (tel) (305) 269 7500 (fax) (305) 269 7599	<b>Australia</b> (tel) 1 800 629 485 (fax) (+61) 3 9210 5947	

**Asia Call Center Numbers**

<b>Country</b>	<b>Phone Number</b>	<b>Fax Number</b>
Singapore	1-800-375-8100	(65) 836-0252
Malaysia	1-800-828-848	1-800-801664
Philippines	(632) 8426802 1-800-16510170 (PLDT Subscriber Only)	(632) 8426809 1-800-16510288 (PLDT Subscriber Only)
Thailand	(088) 226-008 (outside Bangkok) (662) 661-3999 (within Bangkok)	(66) 1-661-3714
Hong Kong	800-930-871	(852) 2506 9233
Taiwan	0800-047-866	(886) 2 25456723
People's Republic of China	800-810-0189 (preferred) 10800-650-0021	10800-650-0121
India	1-600-11-2929	000-800-650-1101

If You Have a Problem  
Before You Call Agilent Technologies

---

# Index

---

## Numerics

6 dB attenuator, [17](#), [22](#)

## A

accessories, [17](#)  
adapter, [17](#), [22](#)  
advanced, [13](#)  
Asia Call Center, [37](#)  
Australia, [37](#)  
avg mode, [12](#)  
avg number, [12](#)

## C

cable fault location  
  meas setup, [12](#)  
cable fault location measurement, [17](#)  
cable fault measurement, [17](#)  
cable loss/m, [12](#)  
cable type, [12](#)  
cable type selection, [18](#)  
cable type selection screen, [19](#)  
cabling errors, [19](#)  
calibrate, [12](#)  
calibrating the system, [17](#)  
Canada, [37](#)  
China, [37](#)  
choose option key, [4](#)  
coaxial cable, [17](#), [22](#)  
coaxial load, [22](#)  
coaxial short, [22](#)  
contacting Agilent Technologies, [36](#),  
  [37](#)  
cost of repair, [34](#)  
customizing cables, [18](#)

## D

directional coupler, [22](#)

## E

Europe, [37](#)

## F

fault symptoms  
  related measurements, [17](#)  
FFT windowing, [13](#)  
function  
  flat top, [13](#)  
  Gaussian, [13](#)  
  hanning, [13](#)

  rectangular, [13](#)

## H

hardware problems, [34](#)  
Hong Kong, [37](#)

## I

impedance, [20](#)  
India, [37](#)  
install now key, [4](#)  
installation disk set, [4](#)  
installer troubleshooting, [5](#)  
installing measurement personalities, [2](#)  
internal source, power level, [14](#)

## J

Japan, [37](#)

## L

Latin America, [37](#)  
license key, [3](#)  
  how to record, [2](#)  
  requirements, [2](#)  
limitation on sweep speed, [31](#)  
loss/gain measurement, [29](#)

## M

Malaysia, [37](#)  
max range, [12](#)  
maximum distance, [14](#)  
meas setup  
  cable fault location, [12](#)  
measurement  
  cable fault location, [17](#)  
  loss/gain, [29](#)  
  return loss, [22](#)  
menu map  
  mode, [10](#)  
menu maps, [9](#)  
mode  
  menu map, [10](#)

## N

New Zealand, [37](#)

## O

obtaining a faster sweep, [31](#)

## P

Philippines, [37](#)  
power divider, [17](#)

## R

reading the measurement, [21](#)  
recording the license key, [2](#)  
reflected energy, [22](#)  
reflected signal, [17](#)  
restore meas defaults, [13](#)  
return loss  
  converting to VSWR, [27](#)  
return loss measurement, [17](#), [22](#)  
RF bridge, [22](#)

## S

sales and service offices, [36](#)  
signal separation device, [22](#)  
Singapore, [37](#)  
span, [14](#)  
stop distance, [13](#)  
store table, [12](#)

## T

Taiwan, [37](#)  
Thailand, [37](#)  
trace points, [13](#)  
transmitted power reflected, [22](#)  
troubleshooting, [17](#)  
  installer, [5](#)

## U

uninstalling measurement  
  personalities, [2](#)  
United States, [37](#)

## V

velocity factor, [12](#)  
video bandwidth, [14](#)  
  automatic, [14](#)  
  default values, [14](#)  
  manual, [14](#)  
VSWR and return loss, [27](#)

## W

warranty, [36](#)  
window, [13](#)

---

## **Index**

---